

Gold recovery in gold pans - the term 'panning'

Robin Grayson

Eco-Minex International Ltd.,
Apt.14, Bldg. 40, 1/40000 Microdistrict, Sukhbaatar
District, Ulaanbaatar 210644, P.O.B. 242, Mongolia.
E-mail: emiweb@magicnet.mn

About the Author



Robin graduated in Geology and Zoology from Manchester University in 1970 where he completed a Masters Degree in Geology before lecturing at Wigan Mining College for ten years. Robin is a specialist in placer gold and ecology and is currently compiling Best Available Techniques (BAT) for Placer Gold Miners. He is Stepegold on the famous Alaska Gold Forum (<http://bb.bbboy.net/alaskagoldforum>).

Purpose of study

The article sets out to clarify the special character of the North American gold pan and why it remains so popular – in spite of widespread dissatisfaction and many modifications and innovations.

The North American pan is distinctive in being circular with a flattish floor ringed by an outwardly sloping wall. Its identity is confused by over-use of the terms 'pan' and 'panning'.

The North American pan gyrates in a distinctive orbital motion driven by both hands of the panner. Although many other motions are resorted to (tapping, to-and-fro, tilting, and tick-tock), it is the orbital motion and flattish floor that together distinguish the pan from most other hand-held gravitational devices.

In spite of its enduring popularity, no scientific tests have been published on the North American gold pan or for any of the innovations covered by 30 US patents awarded since 1861. It remains unclear if the North American gold pan is more efficient at recovering fine gold and flat gold than is a lotok, batea, dulang, ninja bowl, grizzly pan, mat, bucket or any other sort of hand-driven gravitational device.

Some innovations are long-forgotten but merit attention. For instance, bars to keep the panners hand clear of the water, cables to hold large heavy pans, and several pans designed for panning without any water.

Traditionally the North American gold pan was a combined digging and washing device, but today most models are not designed for digging and require a spade to be used.

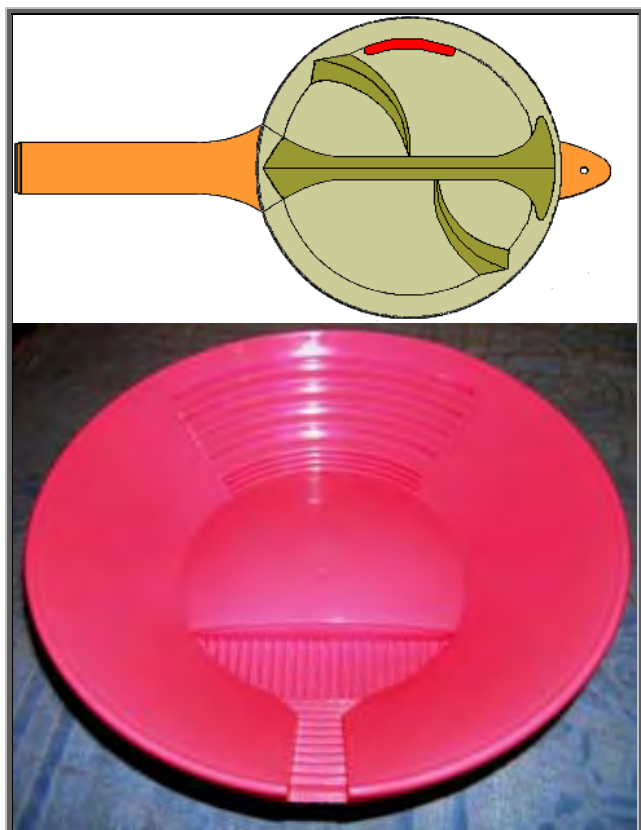

Figure 1.

TOP: an innovative design of 1923 intended for dry panning. BELOW: an innovative new design, the Trinity Bowl of Arizona, incorporating numerous ruffles, and even a pink option in plastic. (photo: Robin Grayson)

What is a gold pan?

Gold pans belong to the diverse group of gravitational gold recovery devices that are driven directly by hand without handles, gears or other mechanical means [1,2]. This group includes not only the classic gold pan but also the bowl-shaped batea [3] of South-Central America, conical dulang [4] of South-East Asia, ninja bowl [5] of Mongolia, bucket [6] of Kyrgyzstan, lotok [7] of Russia, and rubber mat [8] of Mongolia, and other traditional devices, as well as recent innovations such as the grizzly pan [9] and trinity bowl [10].

The term 'panning' has been used rather indiscriminately to all these devices, without proper attention to first determining if the motion of the operator and device are similar in each case, and if the actual concentrating process are closely comparable.

The term 'panning' retains merit as an everyday expression for all washing devices that are directly driven by hand movements; but it is counterproductive in assessing devices as diverse as the pan, lotok, batea, dulang, bucket, ribbed mat and washing-up bowl.

The following account is restricted to the classic gold pan of North America and its direct descendants.

Gold pan – history and origin

The device arose during the mid 1800s and spread with remarkable speed. The author has not sought to determine the origin of the North American gold pan, but offers the following suggestions. Three alternative origins merit consideration:

- ✘ from a modification of the Spanish/Mexican batea;
- ✘ from a domestic frying pan minus its handle; or
- ✘ technology transfer from elsewhere of a miner's gold pan.

The batea is an open conical dish, often with a small central depression. The batea has been widely used in south-central America for centuries before the gold rushes of North America and the batea should have immediately rushed north – it did not. The batea was originally made by carving and turning timber to produce a wooden thick-walled wide slightly conical dish capable of floating or at least possessing neutral buoyancy. Later a partial shift to a thin-walled batea made of metal occurred, the metal allowing the batea to be heated for cooking – and to drive off mercury from amalgam to leave gold.

The author suggests the North American gold pan arose from a domestic frying pan by the simple expedient of removing the handle. It is for style a frying pan is flat-floored; it ensures the maximum surface contact with a hot stove, and stability on the stove and later on a table.

The third alternative is that the miner's gold pan was imported 'ready-made' from elsewhere. This is plausible, and there is evidence that the novices in the 1840s gold rushes in California gained know-how about equipment from seasoned placer miners arriving from the 1830s gold rush of Georgia. In which case they brought miner's pans with them or said "frying pans are the next best thing". The author has witnessed this; half a world away and 150 years later, in Kyrgyzstan (see figures 2, 3 and 4).



Figure 2. Artisanal miner loading concentrate from the ribbed rubber mat into an aluminium pan. Kyrgyzstan. (photo: Robin Grayson)



Figure 3. Panning in the same manner as for the North American Gold Pan. Kyrgyzstan. (photo: Robin Grayson)



Figure 4. The aluminium pan is a basic frying pan with the handle removed. Kyrgyzstan. (photo: Robin Grayson)

Earliest North American pans

Gold pans were widely used in North America since the 1830s but the first was patented only in 1861 – the first 30 years of innovation await study by historians.

By 1861, North American gold pans were diverse, of “sheet-iron, tin or wood” and John Brock (1861) of Chicago wrote, “The sheet-iron pans are mostly made by machinery by being pressed into shape from a single piece of sheet-iron of proper dimensions. Some are made by the old plan of cutting the sheet-iron and seaming together. Some are made of wood, generally turned.”

Gold Pans – US patent search

Conducting a patent search used to be an expensive slow affair, best left to patent expert. This remains true of most patent offices, but not so for the United States Patent and Trademark Office (USPTO) who put their vast archive of US patents on internet at www.uspto.gov. Searching the USPTO archive has been made even easier by Google’s patent search engine www.google.com/ptshp which allows a word search of US patents.

Using these tools, the author conducted an internet search for US patents past and present for gold pans with assistance of members of the Alaska Gold Forum.

Patent classification systems are of necessity cumbersome and idiosyncratic. The technical meanings of words drift over time, and the patent classification system is revised to keep pace of innovations, further adding to the challenge of a patent search.

The author made progress by paying attention to older patents listed as prior art by inventors in their patent documents. However, all lists of prior art are complete, although several feinted perfection while curiously silent about the most relevant prior art.

In checking a patent application the Patent Examiner attaches a list of patents he/she reviewed but the present study showed that all such lists to be woefully incomplete.

Upon finding a relevant patent, each page was then downloaded from the USPTO website using free AlternatIFF software. The pages were then converted into a single Acrobat pdf file using Adobe Professional software. Having learned the procedure, several patents could be downloaded simultaneously.

Result of patent search

The results of the patent search are presented in figure 5. A total of 39 US patents were unearthed for gold pans, awarded between 1861 and 2003. None seem to have been awarded in the interval 2004-2007, although the Trinity Bowl is ‘Patent Pending’, making a grand total of 40 gold pans in figure 5 (see opposite).

In spite of the magnitude of the search, it is surmised that perhaps half a dozen or more patents for long-forgotten gold pans remain as yet undiscovered.

checklist of US patents for gold pans				
award	inventor	patent	location	state
n/a	Trinity bowl	pending	Surprise	Arizona
2003	Matt Kelava	D#475,727	Victoria	AUSTRALIA
2000	Clarence W. Ashcraft	#6,095,342	Mount Vernon	Illinois
1997	Alexander Rosman	#5,667,076	Pomona	California
1993	Robert E. Remias	#5,190,158	Ashland	Oregon
1987	Leo Ottrok	#4,671,868	Oroville	California
1983	Charles Gordon Jr.	#4,400,269	Montclair	California
1982	Ralph H. Morgan	#4,319,994	Sunnyvale	California
1981	Jay. W. Litrap	#4,289,241	Seattle	Washington
1981	Robert E. Legg	#4,273,648	Fremont	California
1979	Roy Lagal	#4,162,969	Lewiston	Idaho
1975	Manuel P. Lawrence & Kenneth F. Jacobson	#3,899,418	Carson City	Nevada
1974	Russell D. Stephenson	#3,855,119	Sonora	California
1968	William H. Klein	#3,407,933	Bainbridge Is.	Washington
1962	Eric S. Smith	#3,059,776	Seattle	Washington
1957	Bruce A. Kress	#2,797,809	Clarkston	Washington
1953	Frank S. Streng	#2,630,226	Black Hawk	Colorado
1939	William L. Boekel	#2,178,390	San Francisco	California
1934	Joseph E. Danills	#1,972,645	Grants Pass	Oregon
1934	Joseph P. Ryan	#1,966,359	Monica	California
1934	Otto K. Nicolai	#1,948,797	Wallace	Idaho
1923	Edward O.C. Ord	#1,444,752	Berkley	California
1922	Edward O.C. Ord	#1,419,405	Berkley	California
1919	Edward O.C. Ord	#1,292,364	Comache	Oklahoma
1913	Edward O.C. Ord	#1,064,854	Pinal	Arizona
1913	Edward O.C. Ord	#1,064,853	Los Angeles	California
1909	John M. White	#923,392	Selma	Oregon
1907	Penton A. Hardwick	#865,178	El Paso	Colorado
1906	Thomas Hussey	#840,333	Hollywood	California
1905	Josef Johansen	#799,059	Parimbo	SURINAME
1901	Archibald Campbell	#667,969	Santa Barbara	California
1900	John Tobin	#664,066	Brooklyn	New York
1900	Walter George Collins	#646,382	New South Wales	AUSTRALIA
1899	William Henry Moore	#634,120	Deadwood	S. Dakota
1897	Samuel G. Stoodley	#618,918	Toronto	CANADA
1897	Fredrick Sletcher	#585,989	San Francisco	California
1896	James Miller	#569,113	Algoma, Ontario	CANADA
1892	Arthur L. Dana	#481,550	El Paso	Colorado
1863	Thomas Kendall Sr.	#37,758	San Francisco	California
1861	John A. Brock	#32,115	Chicago	Illinois

Figure 5. Checklist of US patents awarded for gold pans.

Gold pans – narrow definition

Gold pan - definition

The author recommends the following narrow definition a gold pan of North American type: **A shallow pan consisting of a flat (or nearly flat) floor bounded by a circular wall that slopes outwards to the circular edge of the device. The device is driven manually, by grasping the pan in both hands.**

Gold pan - motion

The design determines the unique motion of a gold pan. The standard motion is imparted by grasping the edge of the pan by both hands simultaneously, and moving the hands to induce the geometric centre of the pan to move in a circular to elliptical path. During its orbit, the pan may be held level or tilted away from the operator. In addition to simple orbits, many other motions can be imparted, including rocking, tapping, knocking, twisting, spinning, to-and-fro, side-to-side, tick-tock etc.

Gold pan – excluded designs

Of the 39 US patents for gold pans, all belong to the to the diverse group of gravitational gold recovery devices that are driven directly by hand without handles, gears or other mechanical means [1,2]. This excludes the large array of inventions that are mechanical pans based on the reverse helix, commonly known as gold wheels.

A review of the 39 US patents for gold pans showed 10 devices fall outside the narrow definition of a gold pan and are marked in red in figure 6 (opposite).

Dana's Ore Washer and Concentrator (#481,550) is close to a lotok in being a trough moved to-and-fro [7].

Miller's Alluvial-Gold Washer (#569,113) is unique, being unlike any other gold recovery device known to the author. It is half a cylinder that is rolled to-and-fro.

Stoodley's Pan for Washing Gold (#618,918) is a deep bowl with a hemispherical, rather than flat, base.

Campbell's Assaying Device (#667,969) has an elliptical bottle shape for assaying rather than panning.

Jonhansen's Miner's Washing Pan (#799,059) is a South American batea and therefore lacks a flat base.

Hussey's Miner's Gold Pan (#840,333) is an oblong set of trays primarily for to-and-fro motion [7].

Klein's Method and Device for Gravity Separation of Particles (#3,407,933) is unique, being unlike any other gold recovery device known to the author. It consists of a flexible cone which on kneading causes gold to migrate to the bottom, but lacks a flat base.

Litrap's Gold Pan and Classifier (#4,289,241), Gordon's Gold Pan (#4,400,269) and Ashcraft's Hand-held Classifying Device (#6,095,342) are oblong devices intended mostly for to-and-fro motion [7].

These interesting, important and often advanced devices are not considered further here and merit further study collectively and individually.

to-and-fro devices in US patents				
award	inventor	patent	motion	comment
n/a	Trinity bowl	pending	⊙	
2003	Matt Kelava	D#475,727	⊙	
2000	Clarence W. Ashcraft	#6,095,342	↔	Grizzly Pan
1997	Alexander Rosman	#5,667,076	⊙	
1993	Robert E. Remias	#5,190,158	⊙	
1987	Leo Ottrok	#4,671,868	⊙	
1983	Charles Gordon Jr.	#4,400,269	↔	Gordon Pan
1982	Ralph H. Morgan	#4,319,994	⊙	
1981	Jay. W. Litrap	#4,289,241	↔	LeTrap Pan
1981	Robert E. Legg	#4,273,648	⊙	
1979	Roy Lagal	#4,162,969	⊙	
1975	Manuel P. Lawrence & Kenneth F. Jacobson	#3,899,418	⊙	
1974	Russell D. Stephenson	#3,855,119	⊙	
1968	William H. Klein	#3,407,933	unique!	flexible cone
1962	Eric S. Smith	#3,059,776	⊙	
1957	Bruce A. Kress	#2,797,809	⊙	
1953	Frank S. Streng	#2,630,226	⊙	
1939	William L. Boekel	#2,178,390	⊙	
1934	Joseph E. Danills	#1,972,645	⊙	
1934	Joseph P. Ryan	#1,966,359	⊙	
1934	Otto K. Nicolai	#1,948,797	⊙	
1923	Edward O.C. Ord	#1,444,752	⊙	
1922	Edward O.C. Ord	#1,419,405	⊙	
1919	Edward O.C. Ord	#1,292,364	⊙	
1913	Edward O.C. Ord	#1,064,854	⊙	
1913	Edward O.C. Ord	#1,064,853	⊙	
1909	John M. White	#923,392	⊙	
1907	Penton A. Hardwick	#865,178	⊙	
1906	Thomas Hussey	#840,333	↔	trays
1905	Josef Johansen	#799,059	batea	conical
1901	Archibald Campbell	#667,969	assay	specialised
1900	John Tobin	#664,066	⊙	
1900	Walter George Collins	#646,382	⊙	
1899	William Henry Moore	#634,120	⊙	
1897	Samuel G. Stoodley	#618,918	bowl	curved base
1897	Fredrick Sletcher	#585,989	⊙	
1896	James Miller	#569,113	↔	roll trough
1892	Arthur L. Dana	#481,550	↔	lotok-like
1863	Thomas Kendall Sr.	#37,758	⊙	
1861	John A. Brock	#32,115	⊙	

Figure 6.

⊙ devices used in the traditional orbital manner of a pan.
↔ devices used mainly to-and-fro and thus not strictly pans.

Gold pans – slope of circular wall

In understanding and classifying gold pans, it is helpful to pay attention to the angle of slope of the circular wall that surrounds the flat central area.

Among the US patents, from the mid-1800s to the present day the preferred angle of the inward slope of the circular wall is in the range of 40-50 , with a preference of 45 . No gold pan seems to have a slope steeper than 55 , and few had slopes less than 25 .

The effect of the slope on the overall dimensions of the gold pan merit attention. The gentler the inward slope then, for a pan of a given diameter, the smaller the area of the flat central bottom. Therefore the gentler the slope the less the device conforms to a North American pan and the more it starts to resemble a South American batea (figure 7). A good example of a batea is the subject of a 1905 patent by Josef Johansen (#799,059).

If the diameter of the pan is increased, then the steep-sided version resembles an artisanal gold pan made by removing the handle from a modern frying pan, as seen in Kyrgyzstan (figure 8).

If the pan is small, or its circular wall is high, then the gently sloping variant may entirely lack a flat central area, and the term 'batea' seems obligatory (figure 9). Indeed if the circular wall is steep and a central flat area is lacking then the term 'dulang' is more appropriate (figure 10) as seen in Laos (figure 11).

The importance of the angle of slope of the circular wall is implicit in all US patents for gold pans, but only in the 1950s did any inventor properly examine the effect of the slope on panning performance. It was Bruce Kress who first developed a hypothesis for wall slope that he presented in 1957 in US patent #2,797,809.

The **Kress hypothesis** might be reworded as: *The angle of inward slope of the circular wall of a gold pan should be in the range of 18 to 26 degrees; less than this and the contents of the pan are likely to remain inert, more than this and the contents of the pan are prone to collapse regardless of the size of the particles or their density.*

If the Kress hypothesis is correct, then the majority of North American pans have outer walls that are much too steep for ease of efficient use. Yet many thousands of recreational miners, prospectors and geologists continue to use steep-sided pans. Possibly the Kress hypothesis is erroneous; more likely the hypothesis is correct but compromised by the overriding desire of the panner to have a central flat area of maximum size to contain the maximum ore and water during the initial wetting, disaggregating and sorting. Only in the later stages of panning does the Kress hypothesis become critical, after the volume of solids and water in the pan have become greatly reduced. Tests and detailed observations are required. It is 50 years since the Kress hypothesis was first propounded; more than 10 North American gold pans have been patented since; all ignore it.

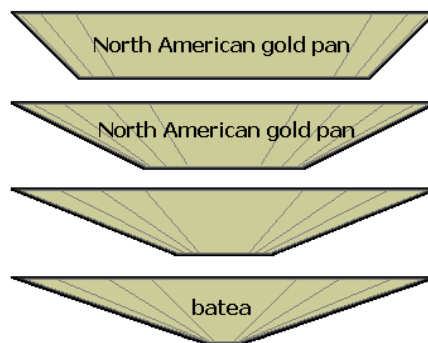

Figure 7.
Trend from North American gold pan to the shape of a batea from South-Central America.

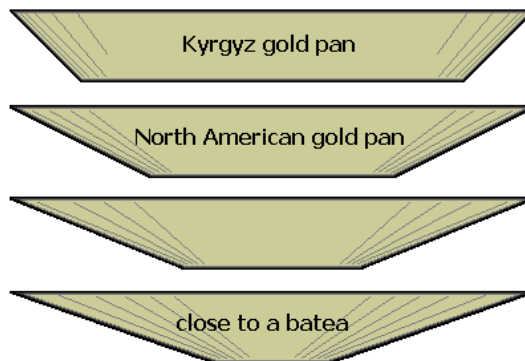

Figure 8.
Trend from Kyrgyz pan through North American to batea.

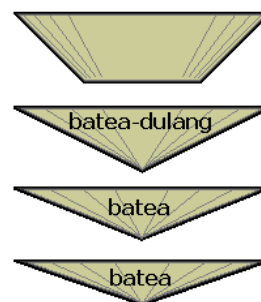

Figure 9.
Trend from deep bowl through batea-dulang to batea.



Figure 10.
Trend from dulang to batea..



Figure 11.
A dulang being used by an artisanal miner in Laos to recover placer gold – the dulang is clearly conical (photo: compliments of HoboTraveler.com - www.hobotraveler.com [1])

First pan patents – 1860s

Brock’s Improved-mining Pan (1861)

The first US patent – for an innovative pan in spite of its simple appearance. Its central floor is covered by a sheet of copper. Mercury locks on the copper as a Cu-Hg amalgam whose mirror-like upper surface amalgamates with gold particles in ore added to the pan. The objective was to lose less mercury and recover more gold.

Kendall’s Paragon Gold Saver (1863)

Another innovative pan, also attempting to curb mercury loss and to increase fine gold recovery. The outer pan is a standard North American pan, modified to have a gently sloping floor to ensure mercury, amalgam and gold drain to a central pocket. This sloped central floor makes the device transitional with a batea. The inner pan fits tightly inside the inner pan and their rims are sealed together. The inner pan is floor-less ore and mercury falls uninterrupted into the outer pan. The inner pan serves as a huge riffle-like dam that retains the gold, mercury, amalgam and most of the black sand when the device is tilted to shed water and lights as tailings.

Pan patents of the 1890s

Sletcher’s Gold-washing Pan (1897)

The first US patent for a modern-style pan. A single riffle ‘rib’ circumnavigates the pan about a third the way up the inwardly sloping wall, to retain heavies. The floor of the pan has 8 banana-shaped troughs to catch heavies prone to slide out of the pan when it is tilted ‘north’ by the panner. To empty the contents of the troughs the panner rotates the device through 90° in order that one end of each banana is now tilted north. The heavies in the escaping material are then retained by the riffle rib that rings the pan wall.

This particular pan is designed to face north or 90° from north (i.e. east or west) but not south; it cannot be termed a ‘Janus pan’ (see below).

Moore’s Prospector’s Pan (1899)

The second US patent for a modern-style pan. Half the inwardly sloping wall is smooth, half is covered with about 10 small riffles. The inventor claims his pan is a combination, achieving the same as two different pans. During the first stage of panning the riffled portion is tilted ‘north’ away from the panner, and lights are ejected while gold is retained by the riffles. Later, to catch small gold, the panner first rotates the pan 180° so that the smooth portion of the pan is now tilted ‘north’. The inventor claims that it is easier to see small gold on the smooth surface than on the riffles.

When pans are can face in diametrically opposite directions (‘north and south’) for accomplishing different tasks, the author suggests the term ‘Janus pans’.

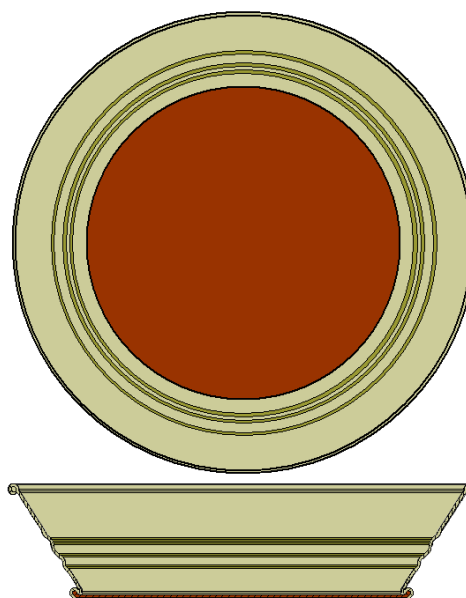

Figure 12. JOHN A. BROCK – 1861

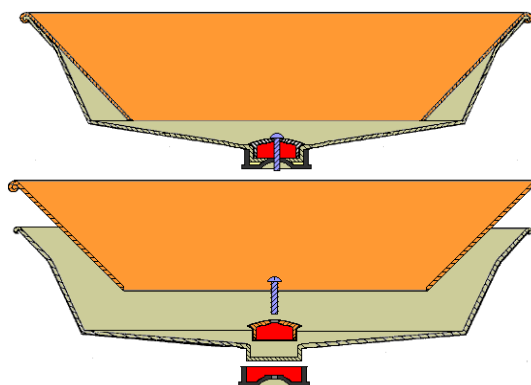

Figure 13. THOMAS KENDALL Sr – 1863

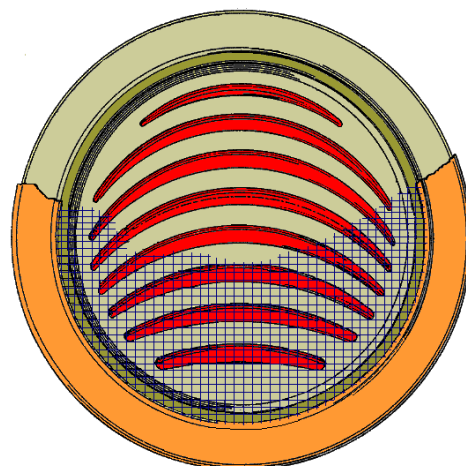

Figure 14. FREDRICK SLETCHER – 1897

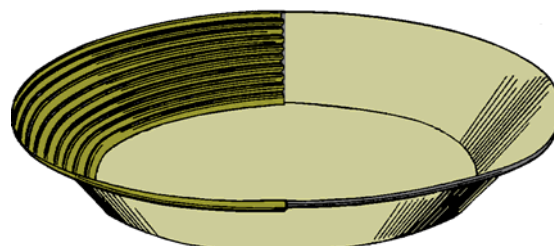

Figure 15. WILLIAM HENRY MOORE – 1899

Pan patents of the early 1900s

Collin’s Prospecting Dish (1900)

By adding a single protruding riffle (rib) around half the circumference of a plain pan, sited near the top of the inwardly sloping wall, a versatile gold pan results. The solitary riffle is *“about three-eighths of an inch in width and is placed about an inch from the top...”* The riffle is a horizontal plate, and when the pan is tilted ‘north’ with the riffle hemisphere to the north, then the riffle ledge stands vertical as the wall is inclined at 45°. The riffle ledge creates a distinct pocket for trapping heavies.

Final cleaning is done by the panner first rotating the pan 180° in order to recover small gold on the smooth wall of the pan tilted north. This is a Janus pan.

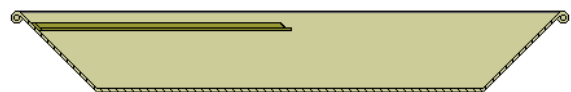
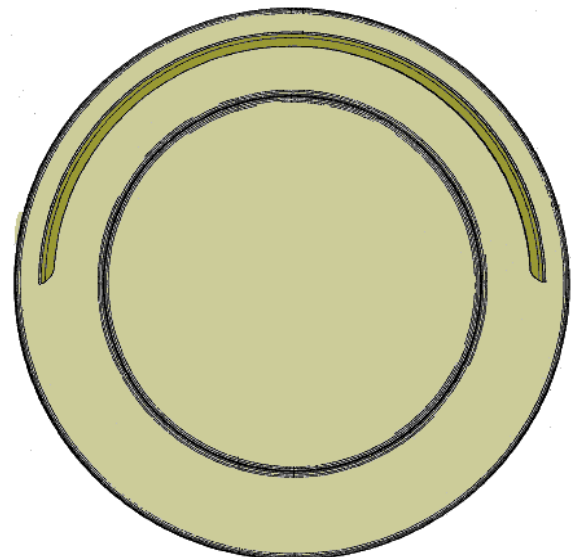

Figure 16. WALTER GEORGE COLLINS – 1900

Tobin’s Prospecting Pan (1900)

An innovative pan, equipped with a defensive shield that extends half way round the inwardly sloping wall. The panner tilts the shield end down to the north, and this allows rapid aggressive panning through loose wet gravel with little fear of ejecting gold from the pan. The shield also serves as a single giant riffle underlain by a huge pocket that retains material. Four rows of holes allow water to flush and drain the lower part of the shield. The shield is braced by a bracket at each end and a line of bolts along its downward edge.

After the rough panning, the panner flushes the contents of the shield into the central flat disk. Final cleaning is done by the panner first rotating the pan 180° in order to recover small gold on the smooth wall of the pan tilted north. This is a Janus pan.

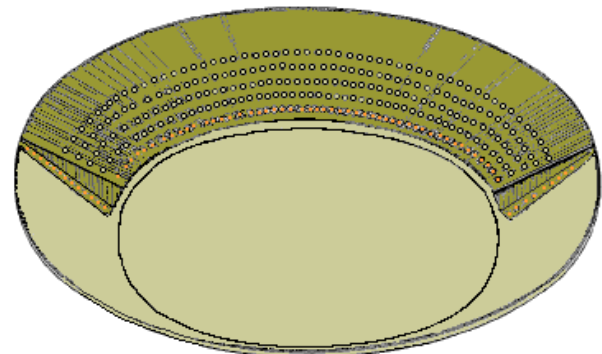

Figure 17. JOHN TOBIN – 1900

Johansen’s Miner’s Washing Pan (1905)

Although termed a “pan” this is a clear example of a batea and is included here to illustrate the difference.

An ‘obvious’ improvement to what the inventor calls *“Mexican bateas”* by carpeting the innermost part of the cone of a batea with cooper sheet. Technically this requires some effort, and a pre-requisite specified by the inventor is to first beat a central depression in the apex of the cone, in order that the copper sheet can be inserted while still keeping smooth the internal wall of the batea. The author also stresses the need for the copper to be as pure as possible and specifically free of iron, and copper rivets to be used to secure the conical copper sheet firmly in position. Furthermore that the heads of the rivets to be beaten as smoothly flush as possible with the shape of the batea.

The objective of the invention is to improve the performance of the batea in recovering gold. Although the inventor refers to *“Mexican bateas”* it is probably significant that the patent says that he was a resident of Dutch Guyana (= Surinam) in South America, where the batea was and remains widespread among artisanal gold miners.

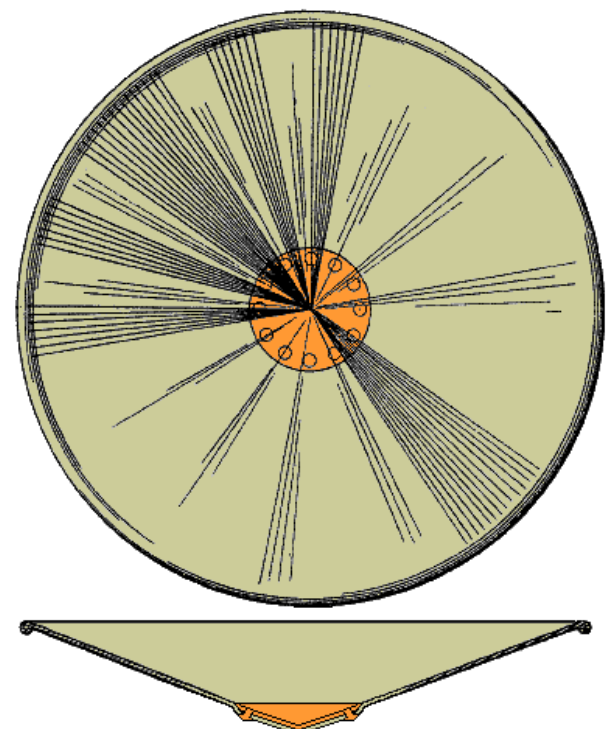

Figure 18. JOSEF JOHANSEN – 1905

Hardwick's Miner's Pan (1907)

At first sight this appears to be a hand-cranked pan. However it is a normal gold pan but with a hand cranked device inserted solely to agitate settled fines in the bottom of the pan.

Slotted into the base of the pan is a highly innovative assembly. The uppermost layer is a coarse mesh metal screen (blue diagonals) held in place by four arms (orange and retaining disk (orange)). Close below the coarse mesh is a medium mesh metal screen (red horizontals and verticals), and beneath that is a fine screen (vertical and horizontal lines) made of taunt cheesecloth or similar fine material.

Beneath the set of coarse, medium and fine screens is a perforate metal disk that helps to support the screens and its large holes allow the fines to fall unimpeded to the bottom of the pan. The inventor includes a ring magnet attached to the perforated disk, with the intention of catching and holding magnetic particles.

Particles that fall through the three screens and pass the magnet accumulate on the floor of the pan. The panner turns the handle periodically to disperse any packed material.

The device is highly innovative and – on paper – sounds convincing. However it is questionable if the pan can be emptied as quickly as the inventor claims, and a panner wants to see the gold appear, or not appear, rather than await disassembly of the device.

The patent breaks new ground for panning, for here in miniature is a pan, three screens, magnetic separator and an anti-packing stirrer.

The device merits building by a precision engineer to allow proper evaluation, and has some features that anticipated the modern Rotapan© of Australia.

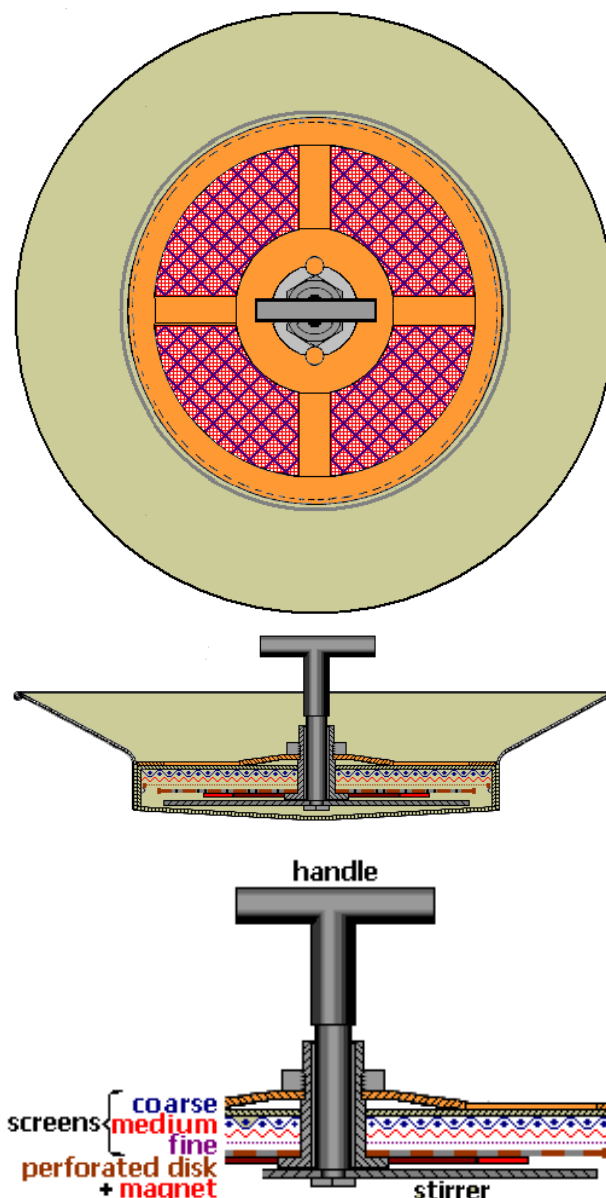

Figure 19. PENTON A. HARDWICK – 1907

White's Pan Riffle (1909)

At first sight this seems to be a simple pan: it isn't. The main feature is a slotted apron the inventor termed a 'riffle'. The riffle occupies about a fifth of the circumference of the rim. It is debatable if the apron can be termed a riffle in the conventional sense, as it also functions as a screen.

A sturdy flange is secured around the top of the remaining bare rim of the pan by a series of spring clips. This flange is a simple giant riffle, although the inventor declines to call it so. By ponding water and sediment, the flange reduces the risk of throwing away valuable concentrate with the tailings. It also channels concentrate towards the slotted apron. In the author's opinion, much depends on the ability of the slotted apron to retain heavies while allowing water to flush away tailings.

By lifting each of the spring clips the entire assembly is detachable. Although the inventor does not mention it, this allows the pan to be dual purpose: first with the giant riffle attached for rough panning, and then with the giant riffle removed for final gentle panning. This is a Janus pan, of sorts.

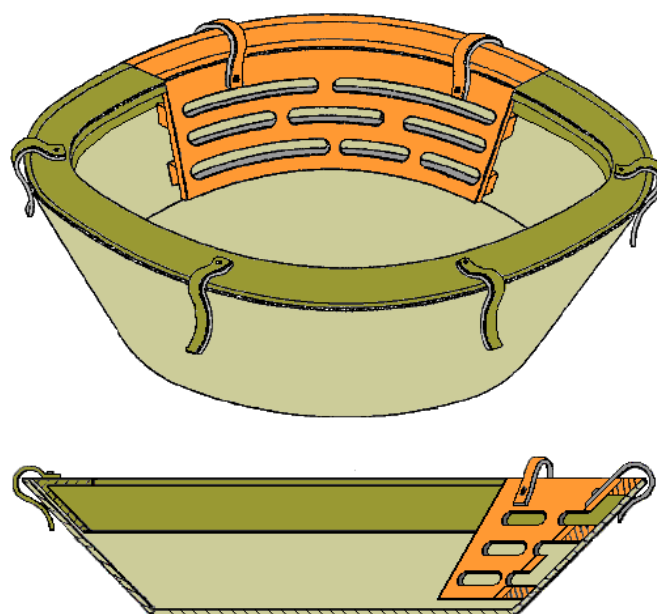

Figure 20. JOHN A. WHITE – 1909

America’s prolific inventor of gold pans – Edward Ord II

In the history of American gold pans, one inventor towers above all others, at least for his bibliography if not necessarily for his pans (see text box).

Ord’s Miner’s Gold Pan (1913a)

Three innovations transform a basic gold pan:

- ✘ **raised central platform** – this creates a circular channel around which the heavies concentrate during the swirling of the pan, and was the forerunner of later patents such as the blue bowl. Tilted in the usual manner to the north, an oval dimple in the trough trapped the heavies. This is a Janus pan.
- ✘ **exit spout** – lowering a section of the outer wall makes a broad ‘spout’. Final panning is facilitated and small gold trapped in a linear dimple. The inventor notes that mercury may be added to the two dimples if desired.
- ✘ **swinging handles** – these allow the panner to keep his/her hands out of the water throughout the panning process.

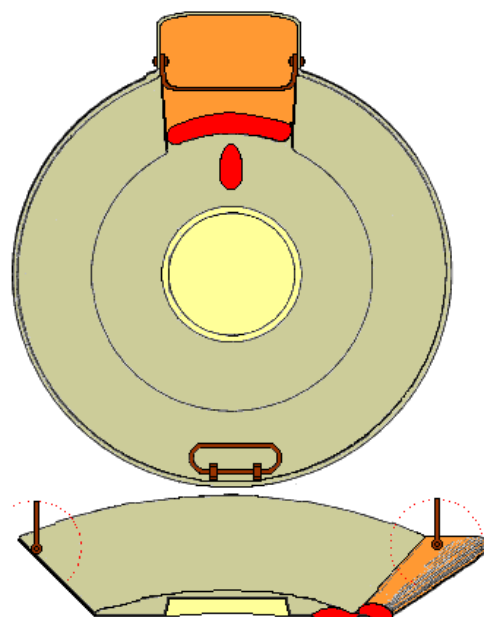

Figure 21. EDWARD O.C. ORD II – 1913b

Edward Otho Cresap Ord was born in Cumberland, Maryland, on 18th October 1818, the son of James Ord and Rebecca Ruth (Cresap) Ord. After receiving a West Point appointment from the District of Columbia, Edward Ord graduated from the military academy in 1839. He served in the Seminole War, the Mexican War in California, and the American Indian wars. On 14th October 1854, he married Mary Mercer Thompson. Ord saw extensive action in the American Civil War, most significantly as commander in one of the North’s earliest victories at Dranesville, Virginia; as a prominent participant in the siege of Vicksburg; and as a major force in the final drive against Richmond and Petersburg that culminated in Appomattox. After the war, Ord commanded the departments of Arkansas, California, Texas, and the Platte. In 1881, he retired from the army. Edward Otho Cresap Ord I died in Cuba in 1883. He is buried in Arlington National Cemetery.

Edward Otho Cresap Ord II, the son of Edward Otho Cresap Ord and Mary Mercer (Thompson) Ord, was born on 9th November 1858 at Benicia Barracks, California. After attending public schools in San Francisco and Omaha, he was appointed to the U.S. naval academy in 1876, only to withdraw a year later. In 1879 Ord became a second lieutenant in the 22nd infantry. He soon saw action in the American Indian campaign in Texas and the campaign against Sitting Bull in 1891-1892. His 22nd infantry was among the first American troops to enter Cuba in the Spanish-American War in 1898, and his unit experienced heavy fighting. Following duty suppressing a rebellion in the Philippines, Ord retired from the army on account of disabilities sustained in Cuba. Ord continued his military pursuits as a military aid to the Arizona governor and served on the Mexican border. In April 1912 and April 1913 Ord filed patents for innovative gold pans, and duly awarded patents in 1913. In 1918, he retired to California and was awarded more patents for gold pans in 1919 and 1922. Edward Otho Cresap Ord II died on the 4th April 1923 at Eagle Rock, California.

Ord’s Miner’s Gold Pan (1913b)

The application was submitted second but awarded first; it takes the innovative Ord pan a stage further:

- ✘ **swinging ropes** – adding ropes allow the pan to be submerged and the panner keep his/her hands out of the water and yet swing the pan by tugging on the ropes. This is much less tiring and allows greater throughput per hour – potentially industrial-scale if properly organised.
- ✘ **central vanner** – in Ord’s earlier invention, the raised central platform served only to create the circular channel. Now the platform is gently sloped to its centre for cleaning up the final concentrate. Ord termed it a vanner and it resembles a miniature batea in simplicity and gentle slope.

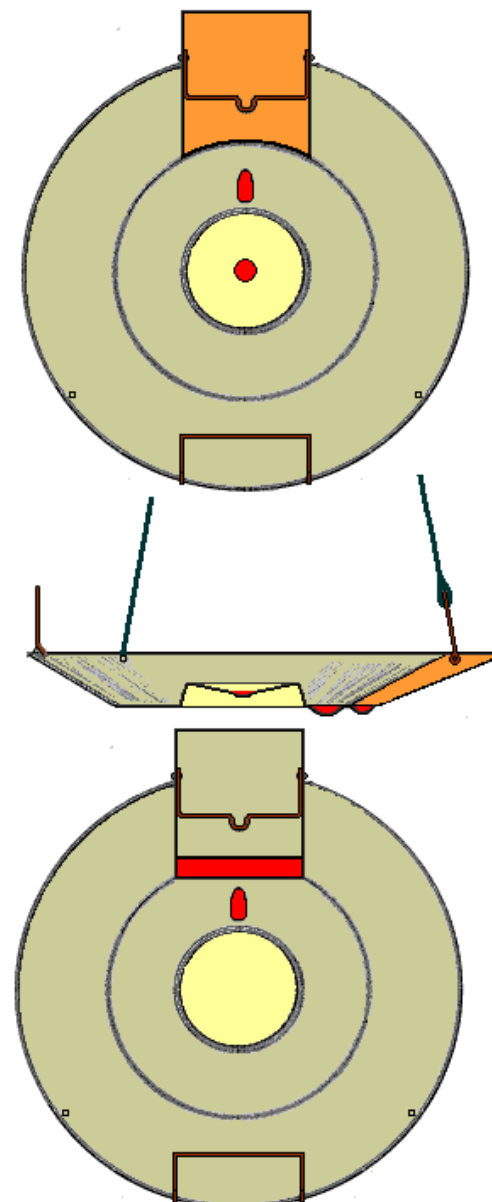

Figure 22. EDWARD O.C. ORD II – 1913b

Ord's Gold Miner's Pan (1919)

Ord developed his gold pans further and in 1919 was awarded a patent for "certain improvements over the gold pans shown in my similarly entitled prior United States Patents...". The innovations had three main goals:

- ✘ "so constructed that a whirling, spinning or centrifugal motion may be readily imparted thereto..."
- ✘ "...this motion arrested and reversed in direction quickly in order to effectively and expeditiously recover gold..."
- ✘ "...for receiving and separating large quantities of heavy material, in which the pan is adapted to be suspended from above and allowed to rest on a central pivot point about which the operator may conveniently rotate [the pan]."

A pair of stout metal rods straddles the pan. Grasping them the panner can impart a sudden reversal of motion to the pan. The metal rods also allow ropes to be attached from above in order to suspend the pan. As in the 1913b patent this enables panning to be much less tiring for the operator and allows a much greater throughput.

The once-flat central platform of 1913a has evolved through the 1913b batea-like "vanner" for final upgrading into the 1919 batea proper for bulk concentrating. A choice of simple cone or convex-down cone is added.

Ore is put on the platform and the circular channel filled with water. Panning begins by tilting the pan from side-to-side to induce water to pass in waves over the platform, "in this way washing the original sample gently out of the vanner until nothing remains there except the metal contents of the original sample, the sand and gravel having been washed into the annular channel..."

The problem of how to remove the valuable gold concentrate from the centre of the platform is solved by means of a tap hole and discharge plug from below.

The central discharge plug also serves as a central pivot upon which the pan can be "rocked for certain separating purposes". This allows a wobbling action, a tilting action or a controlled spin – with little effort.

The circular channel is now the dump site for tailings. Indeed the inventor suggests an optional screen over the central platform and this would deflect oversize to the the channel. Larger stones are removed by hand, and then the tailings rewashed by circular motion of the pan.

In a further innovation, much of the outer wall of the pan is fluted to impart "repeated shocks" to disaggregate resistant clay. Recovery from the central channel is by tilting north to trap heavies in a dimple (with a tap hole) and intercepting escaping gold by four oblique grooves.

The 1919 patent also presents a modification to facilitate "laboratory work". This has a narrow channel added to circumnavigate the central platform near to the top of the rim. Adding this extra channel enables, "repeated washings from the outer channel to enter readily the centre vanner and permit oil floatation tests on sand concentrates...". This is a remarkable and tantalising remark. It may be that Ord was experimenting at the time with oil floatation methods of gold recovery, especially of fine gold. Alternatively Ord may have revealed in his off-hand remark a novel way of checking for the presence of fine gold by forcing it to float.

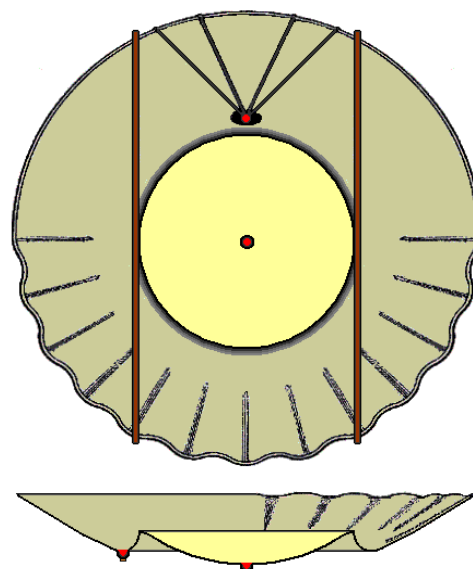

Figure 23. EDWARD O.C. ORD II – 1919

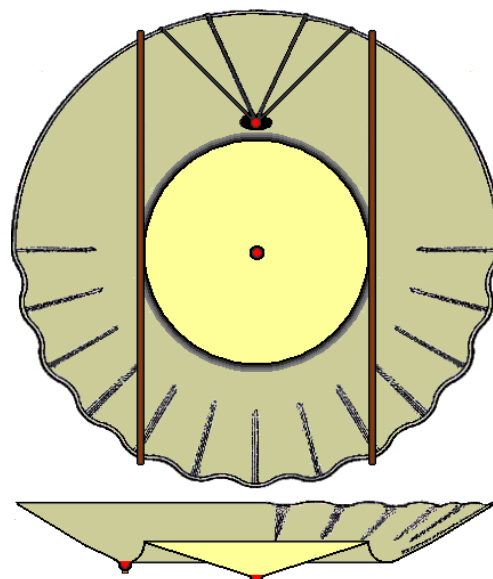

Figure 24. EDWARD O.C. ORD II – 1919

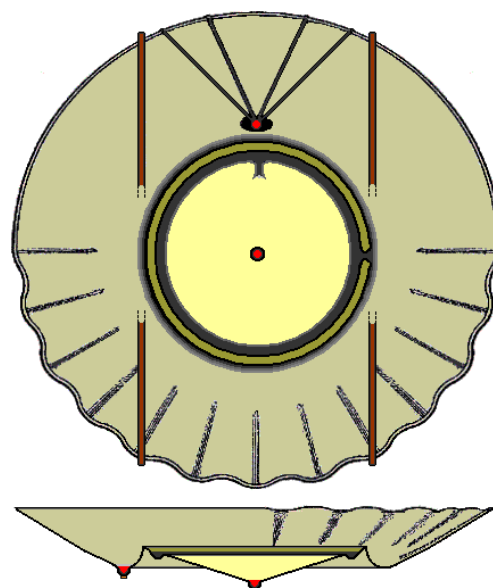

Figure 25. EDWARD O.C. ORD II – 1919

Ord's Gold Pan (1922)

Ord was awarded a patent in 1922 for fundamentally different pans "capable of use either with the sand wet or dry as conditions may require." Although the inventor does not actually describe the panning method, it is evident that he intends the new pans to be used either with or WITHOUT water. Clearly this extends the versatility of panning to arid regions.

The innovation begins with a plain pan into which a central rib is inserted to partition the pan into two chambers. The top of the rib is lower than the rim of the pan to prevent the contents sloshing out during panning. As the rib approaches the pan wall, the rib flares outward as ears, the ears being gently concaved inwards and to form corners or pockets where heavies can concentrate.

A minor improvement is the modification of the rim of the pan by one or more trough-like "guide grooves" to permit the pouring out of residues left in the pan.

The inventor comments that the pan wall may be sloped straight or somewhat concave, and may have an optional flange "for convenience in manipulation."

In a variant, a deflecting rib is added to a compartment, and the opposite compartment has one or more pockets countersunk in the bottom of the pan at the base of the pan wall to catch heavies – and to hold amalgam if used.

In a second variant, the partition is no longer a simple rib but a curved rib "oval in cross section, adapted to save the finest gold dust". Instructions are not given on how to use this version of the pan. Again one compartment holds a deflecting rib while the other compartment contains a linear groove as trap.

In a third variant, the pan is elongate, deviating markedly from the circular plan of a classic pan. The central partition is tapered; one end as high as the pan wall, the other end much lower. Again, one compartment has an inwardly projecting tapered rib – wedged in cross section – its outer portion having concave ears to create pockets for trapping heavies. The opposite compartment contains a linear groove as trap.

The inventor comments, "the pans may be made polygonal or irregular in contour if desired" but does not discuss them further and none are illustrated.

Ord's Gold Pan (1923)

Ord developed his 1922 gold pan further and was awarded a second patent in 1923. Again the new pan is to be used with or WITHOUT water. Material is put in one compartment of the divided pan. Water is added to cover the sand. The pan is held by the handle and tilted slightly toward the opposite side and a gentle agitation applied. A swirling motion is also used. Heavies fall to the bottom and the lighter sand washed into the other compartment.

The handle "enables the reaching for and scooping up sand or gravel... When once charged with sand, this can be shifted all into one side and then water added." Opposite the handle is "a point added to enable breaking through snow or any crust" and "a pick point" to clear obstructions. If the pan is large for large work, the shovel end acts as a pivotal support and the handle a lever to operate the pan.

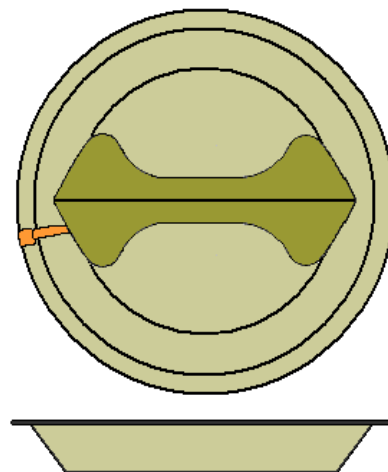

Figure 26. EDWARD O.C. ORD II – 1922

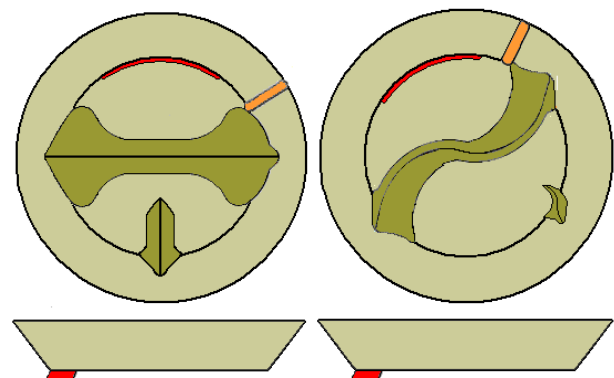

Figure 27. EDWARD O.C. ORD II – 1922

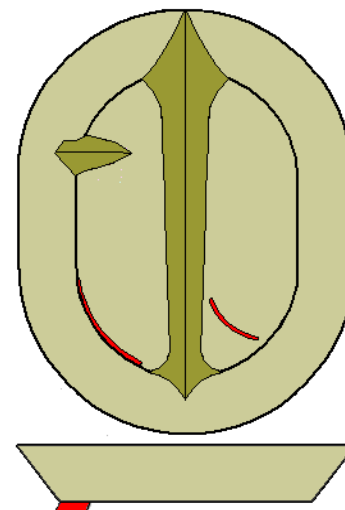

Figure 28. EDWARD O.C. ORD II – 1922

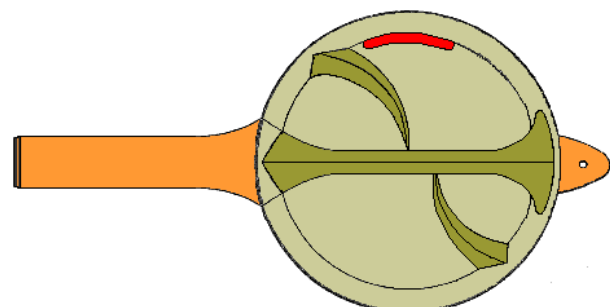

Figure 29. EDWARD O.C. ORD II – 1923

From Ord to World War II

Nicolai's Miner's Pan (1934)

A simple arrangement of two pans consisting of a screening pan inserted into a normal solid-floored gold pan. The inventor claims that this combination increases gold production while reducing the effort demanded. The device is radially symmetrical – this is not a Janus pan.

The screening pan is raised somewhat from the gold pan by means of internal legs. The screen is made either of perforated metal as illustrated opposite, or a metal mesh screen illustrated in the patent. The problem of recovering gold from the gold pan is addressed by means of a central cup that is detachable from below.

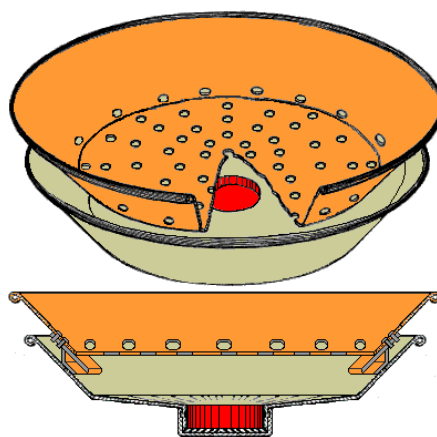

Figure 30. OTTO K. NICOLAI – 1934

Ryan's Mineral Washing Pan (1934)

A simple design with ease of manufacture in mind. The device is a simple flat floored pan whose inclined wall bears essentially S-shaped corrugations to serve as riffles. Four such riffles are illustrated in the patent.

Each of the riffles stops slightly short of completely circumnavigating the pan, so leaving a narrow smooth channel. This makes it a Janus pan.

The channel narrows towards the rim, and the inventor says its main function is when cleaning the pan after the end of the panning process, but also for final upgrading of concentrate.

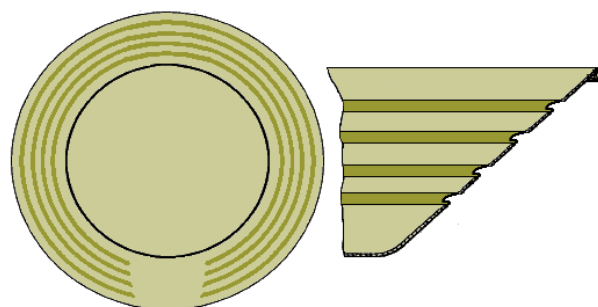

Figure 31. JOSEPH P. RYAN – 1934

Danills's Gold Pan (1934)

A modern-looking design, with riffles extended about half way around the pan. Each riffle is a ledge about half an inch wide. Three riffles are suggested for an 8-inch pan and six for an 18-inch pan. The bottom of each riffle is parallel to the flat bottom of the pan, whereas its top side is "substantially at right angles to the side walls". The sides of the riffle meet in a sharp edge.

The object of this riffle is "to make it impossible to lose any of the gold or heavier metals, also to increase the speed of panning ninety per cent." No test results are presented to support this assertion.

After the gold has settled in the pan, "the pan can be tipped up to an angle of 60 degrees and the pulp all discharged without losing any of the gold or heavier metals."

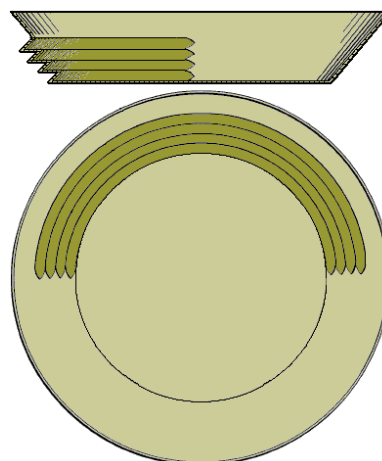

Figure 32. JOSEPH E. DANILLS – 1934

Boekel's Gold Pan (1939)

An innovative pan based on the simple observation that gold tends to collect in the crease where the side wall meets the flat floor. The inventor replaced the crease with a bead-shaped slot circumnavigating the pan in a ring to retain gold that otherwise is prone to be inadvertently ejected during panning. After panning has been completed, the pan is tilted north and clean water used to flush the trapped gold from the ring slot into a tapering spout that is a continuation of the slot as a depressed area of the side wall. The gold and water is thereby transferred safely into a container ("gold flask").

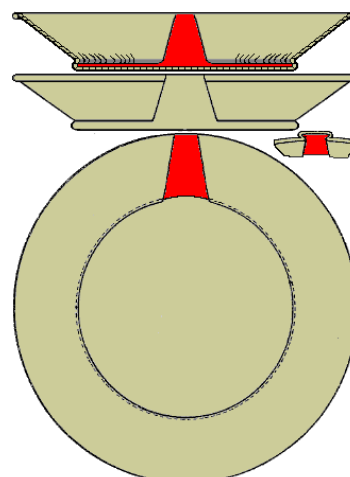

Figure 33. WILLIAM L. BOEKEL – 1939

From World War II to 1970

Streng's Direct Gravity Recovery Gold Pan (1953)

A simple design with low-cost manufacture in mind. The novel feature is a circular funnel trap feeding a cylindrical chamber ("cup") accessible from below by turning the screw thread. Instead of the cup, a conical plug ("finger") can be screwed in and the trap then being confined to the funnel.

The inventor presents drawings of a pan with its floor gently domed to encourage material and water to concentrate around the contact of the floor with the side wall, and so become the main site of heavies to concentrate, inexorably destined for the funnel trap. The inventor mentions the floor can also be flat but did not present such a drawing – the author has added it.

Kress's Gold Pan (1957)

A novel pan, with its wall much flatter than the conventional North American pan. The patent includes the "Kress hypothesis" reworded thus: *The angle of inward slope of the circular wall of a gold pan should be in the range of 18 to 26°; less than this and the contents of the pan are likely to remain inert, more than this and the contents of the pan are prone to collapse regardless of the size of the particles or their density.*

The inventor claims that the gentle slope enables faster panning and easier recovery of small gold.

A second innovation is the use of a tight fitting fine metal mesh screen.

A third innovation is "a canvas or other matting material" put under the screen, clamped taunt between the screen rim and the pan wall, to aid trapping fine gold.

Smith's Gold Pan (1962)

An innovative pan, yet deceptively simple in appearance. Besides making efficient use of sheet metal and low-cost manufacturing, the pan includes important innovations. The pan is said to improve gold recovery and enable "much faster" panning than with a basic gold pan. The pan is for use either with or WITHOUT water, the first pan patent since Ord's in 1923 to make such a claim.

As an example, it is a 15-inch pan with flat bottom 8-9 inches in diameter, with the pan wall sloping at 30-35°. The inventor says, "obviously the bottom of the pan does not need to be flat but can be somewhat concave if desired."

The rim of the pan is bent over outwardly in order to strengthen the rim. However one segment of the bent-over material is bent back again to form an inwardly directed 'rim riffle', termed a "trap" by the inventor.

A further innovation is corrugated riffles in the pan wall below the rim riffle, to agitate material being panned and encourage heavies to be trapped either in the corrugated riffles or in the rim riffle. The author suggests the corrugated riffles act like a miniature concentrating table and direct heavies into the rim riffle.

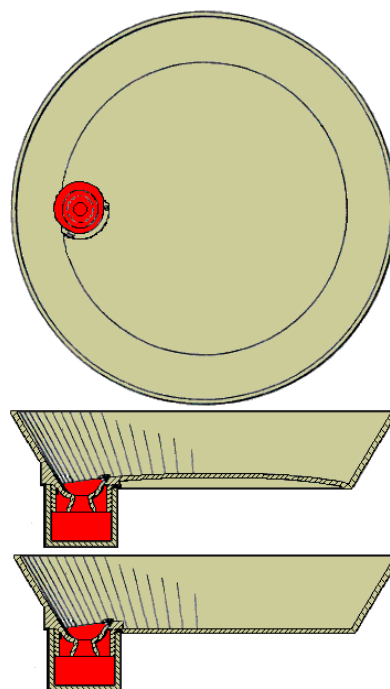

Figure 34. FRANK S. STRENG – 1953

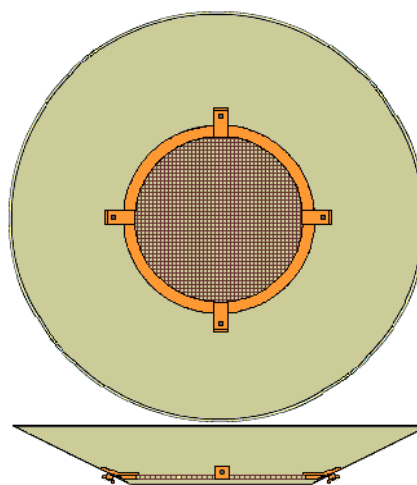

Figure 35. BRUCE A. KRESS – 1957

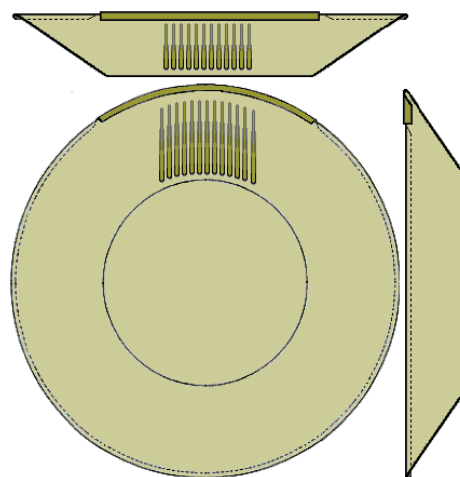

Figure 36. ERIC S. SMITH – 1962

From 1970 to 1980

Stephenson's Gold Pan (1974)

A highly innovative design, quite different from earlier patented pans. A single riffle is integrally formed in the wall of the pan, and the riffle spirals downwards from the rim of the pan to the edge of the flat floor of the pan. The riffle has a pronounced overhang on its lower edge to catch and hold heavies while the lights wash over it.

The pan is used as a bulldozing scoop on the bottom of a stream, with the riffle end of the pan tilting north. During the dozing, the spiral riffle retains the heavies. Alternatively the pan can be swirled underwater in the traditional panning manner, or swirled out of the water.

This unique pan is a link between conventional pans and gold recovery devices known as spirals.

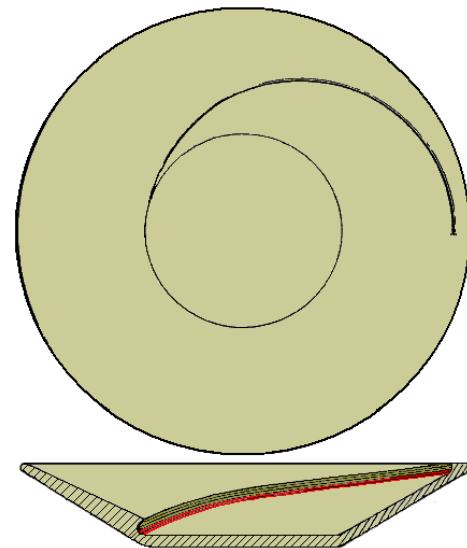

Figure 37. RUSSELL D. STEPHENSON – 1974

Lawrence and Jacobson's Miner's Pan (1975)

Another highly innovative design, quite different from earlier patented pans. The wall and floor of the pan are similar to a traditional round pan, except that the floor is not flat but slopes gently towards the centre.

The pan has several innovative features. It is the first patent for a pan to be made of low-cost thermoplastic, and the first patent to specify clear plastic so that gold can be seen from below.

The trap has a curved bottom, facilitating settling by rocking. The pan is submerged and shaken in an orbital panning manner; pausing to remove oversize by hand. The pan is then slowly raised out of the water, at the same time rocking the pan north-south, ejecting the water and lights northwards. The panner then lifts the pan to check for gold in the central trap, looking through the clear plastic. If no gold is visible, then panning is resumed. If gold is visible, the panner tilts the pan north to channel the contents of the central trap up a series of tiny riffles that retain the heavies while the water and lights continue north along the channel to discharge from the pan rim.

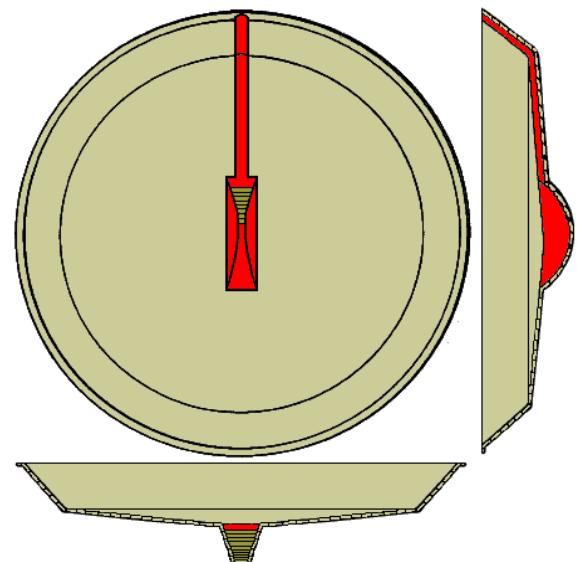

Figure 38. MANUEL P. LAWRENCE & KENNETH F. JACOBSON – 1975

Lagal's Apparatus for Separating Material by Specific Gravity (1979)

The pan is of dark green thermoplastic polyvinyl chloride aiding visual inspection of the pan's contents from above, an innovation followed by most manufacturers. The wall slopes at 30-40°, with 35° being preferred. This is less steep than most contemporaries, perhaps in deference to the Kress hypothesis.

The generous space allows broad riffles on the slope, three riffles being preferred.

The riffles extend for about a third of the circumference of the pan, although the inventor says they can be complete rings.

The riffles are sharp and the angle is 90°. The inventor says that 80-85° "operation of the device is substantially impaired" but does not elaborate.

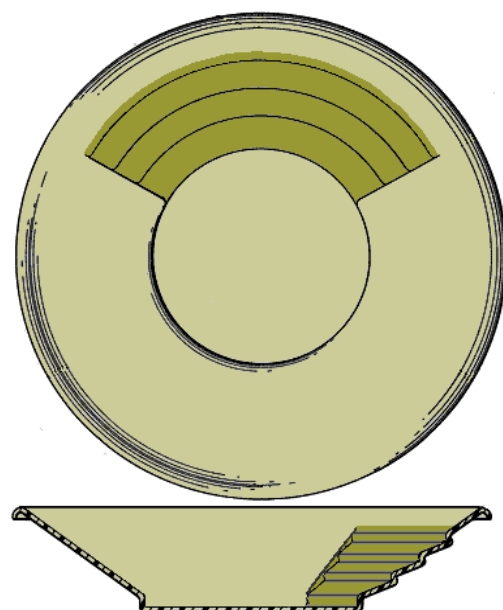

Figure 39. ROY LAGAL – 1979

From 1980 to 1990

Legg's Quick Miner's Pan (1981)

Moulded thermoplastics opened new avenues for inventors, such as this innovative pan. Made of vacuum moulded plastic enabling low cost manufacture, the pan is transparent to permit ease of inspecting for gold. The inventor claims more throughput than a normal gold pan.

The pan is a typical circular gold pan, with the option of ring riffles on the flat floor. The centre of the floor is a trap, leading to a trough which exits the pan from below at 10-45°; the inventor says 15-30° achieve best results. The trough extends beyond the pan, and contains ladder-like steps that constitute riffles. The riffles trap heavy minerals in the trough.

The ladder of riffles is hinged for raising it clear of the trough base, so allowing rinse water from the pan to flush the heavies from the trough into a container.

In a variant, a trough is clipped to the rim of a pan, and periodically the contents of the pan pour down the trough where heavies are trapped by ladder-like riffles.

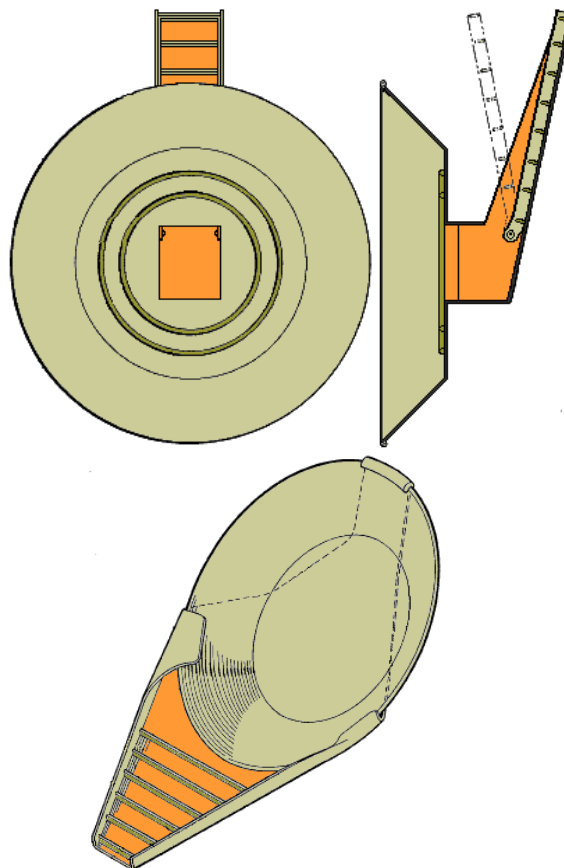

Figure 40. ROBERT E. LEGG – 1981

Morgan's Gold Mining Pan (1982)

An innovative pan very different from earlier pans.

The pan is a typical circular gold pan, highly modified in the middle. The inventor asserts that in a normal pan "gold settles in the first few swirls of slurry" and seeks to recover the gold immediately from below in a manner that eliminates the time and labour of panning away the lights.

The innovation consists of a series of riffle like slots that trap the gold in the otherwise flat floor of the pan. Once accomplished, the panner then pulls a long lever that causes a shutter to shut off the slots and their content of gold. To retrieve the gold, the panner pulls a smaller lever sited beneath the pan that opens the base of the slots allowing their contents to fall into either a bucket or an attached transparent-walled inspection jar.

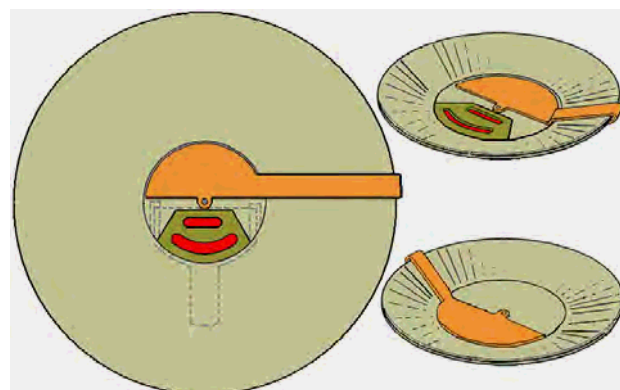

Figure 41. RALPH H. MORGAN – 1982

Ottrok's Method (1987)

"Method for Recovering Gold, Platinum or Silver from an Ore containing Gold Dust, Platinum Dust or Silver Dust."

An innovative pan relying on mercury with risk to health and environment. The floor can be slightly concave or slightly convex, even a batea. The patent uses a simple round gold pan with two half-ring riffles on its wall.

The side of the floor opposite the riffles is modified to be an amalgamation plate of silver plate. Copper is unsuitable as mercury tends to erode it. If the pan's floor is metal, it is silver plated. If the floor is plastic a copper sheet is silver plated and attached to the floor by cyanoacrylic or epoxy adhesive.

A few drops of mercury are put on the silver and gently rubbed over the surface. The panner then pans material in the conventional manner. Very fine gold amalgamates with the mercury as a yellow film that coats the silver plate. The amalgam is scraped off with a plastic spatula and swept in a channel that conveys it to the edge of the pan where it is collected.

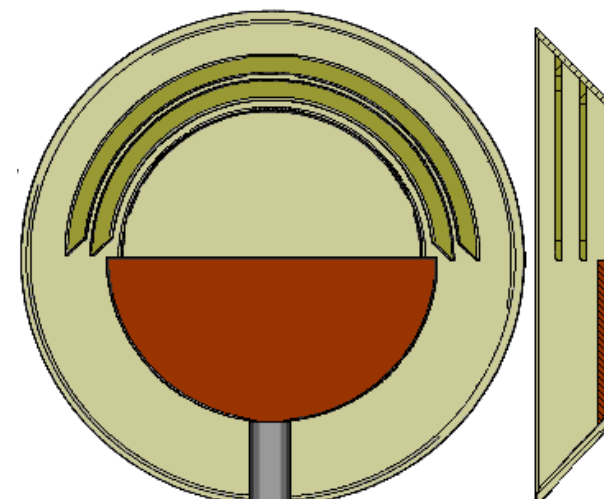

Figure 42. LEO OTTOK – 1987

From 1990 to 2000

Remais' Gold Pan with Classifier (1993)

An innovative device made of tough moulded plastic. It consists of a gold pan and classifier used connected or separately. The pan has a flat floor and its wall has incomplete annular riffles. The pan's floor is circular but the pan's rim is an elongate ellipse in common with the classifier. The classifier slots into the top of the pan, with a narrow space between to allow water to slosh out by tilting the device in any direction.

The elliptical shape bestows some advantages:

- ✘ the device functions better as a scoop or catch basin;
- ✘ the enhanced surface area facilitates collection of sediment dislodged from the side of a river bank;
- ✘ when space is limited, the short end walls can be used; and
- ✘ with or without the classifier, the gold pan can dig slurry.

Typically sediment is put of the classifier's screen for removal of oversize; the fines drop into the gold pan where water is added and the pan swirled, hit, or otherwise agitated to disaggregate material.

While the device is novel, there seems to be only limited advantage, if any, over simpler pans and screens.

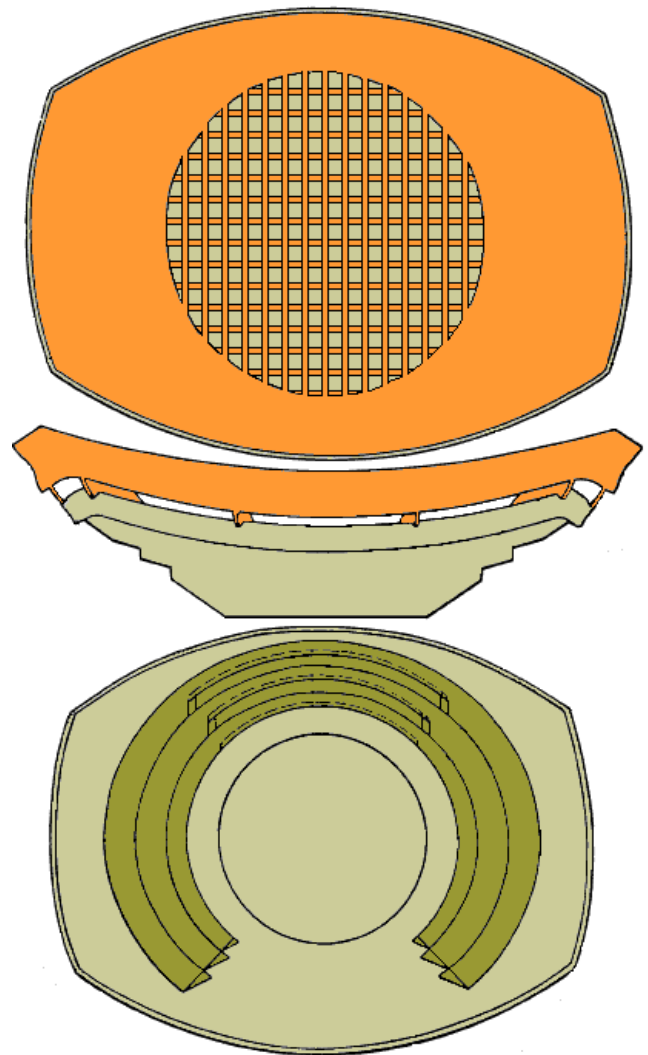

Figure 43. ROBERT REMAIS – 1993

Rosman's Gold Retrieving Pan (1997)

An innovative pan, probably best made of plastic. The pan differs from a conventional gold pan in the wall sloping inward at only 30°, then curving rapidly to 90° at the suture with the flat floor. This sudden curve acts as a circular riffle and causes the suture to be a circular trap for gold.

The most prominent innovation is the presence in the pan floor of a combination of "trap" and "trough", perhaps better termed riffle and dimple.

The device is claimed to be suitable for panning with or without water, and the panning method is rather different than with most other pans, as outlined below.

Panning with water:

- ✘ tilt the pan slightly north and shake about 30 times from side to side without spilling water;
- ✘ tip the pan south and vibrate the pan while moving from side to side until all unwanted sand is opposite the trap;
- ✘ scrape out the unwanted sand from the pan;
- ✘ pour out the dirty water;
- ✘ add half a pint of clean water, NOT directly over the trap;
- ✘ tilt north and shake from side to side;
- ✘ slowly flow the water over the trap and trough; then
- ✘ reverse flow direction until any gold is visible and retrieve it.

Panning without water:

- ✘ add concentrate from a dry washer;
- ✘ shake pan side-to-side 4 to 5 times, keeping the pan level;
- ✘ tip the pan north and shake side to side 30-40 times;
- ✘ tip the pan south and vibrate the pan while moving from side to side until all unwanted sand is opposite the trap;
- ✘ blow lightly over sand near the trap to check for visible gold;
- ✘ remove tailings by tipping the pan away from the trap; then
- ✘ put the sand residue in a container for later retrieval.

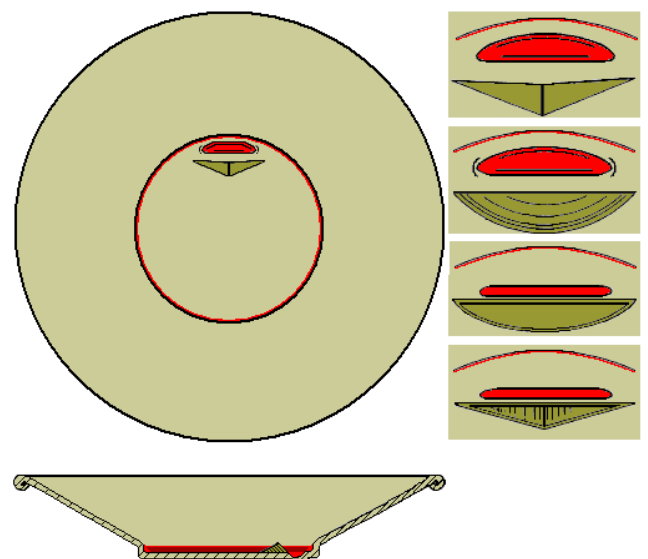

Figure 44. ALEXANDER ROSMAN – 1997

2001 – present – modern North American pans

Kelava’s Spiral Gold Pan (2003)

An innovative pan, economic if made in plastic. The floor is set of spiral riffles arranged around a central cavity. The pan wall is very steep, more so than in other patented pans.

The device seeks to maximise the trapping potential when the panner swirls the pan. As yet no tests have been published, nor any assessment by users.

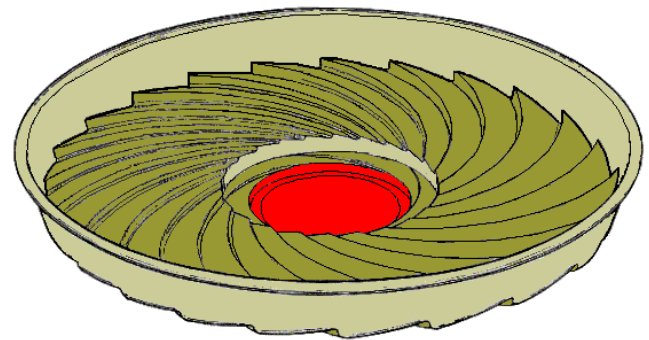

Figure 45. MATT KELAVA – 2003

Lagal’s Gold Pan and its influence

Roy Lagal submitted his patent application in 1977 and it was awarded in 1979. The ‘Garrett Pan’, so branded by the manufacturer, became the market leader for modern North American gold pans, and is now entrenched as the norm of recreational miners, prospectors and western geologists. Garrett’s and its network of distributors still proclaim it as *“the world’s only patented 90-degree riffle design that ensures rapid gold recovery in wet or dry conditions”* even though the patent is long expired. It has stood the test of time, and now the patent has expired it is freely copied by rival manufacturers. For instance the Keene SP-14 Super Pan is very similar.

Often the modern variants include small changes such as increasing the number of riffles, adding rough and smooth textured areas, adding a set of tiny riffles and so forth. For instance, Estwing produce a 350mm (14-inch) diameter extra heavy duty plastic gold pan with two riffle sections built in the wall, coarse Lagal-like riffles and fine *“Chinese riffles and finger-grip rim”*.



Figure 46. The Keene SP-14 Super Pan, a variant on Lagal’s Garrett Pan. (photo: Robin Grayson)

Pro-Gold’s Trinity Bowl

An innovative pan that is ‘patent pending’ is the Trinity Bowl produced by Pro-Gold Prospecting and Equipment Supplies, based in Arizona. The pan is deep compared with most other pans, and has fairly steep sides, leading it to be termed *“bowl”* by the manufacturer yet in all other respects it is a North American gold pan.

The floor is domed (convex) driving the heavies to the junction with the base of the wall. This is a Janus pan.

One end of the pan is dominated by a set of riffles – four moderately large and triangular in section, and lower down three extremely narrow riffles that constitute slot-traps.

The opposite end of the pan has a slot channel trough with a set of 9 riffles each of triangular section. The trough extends down from the rim of the pan to the floor where it meets 21 riffles again of triangular section.

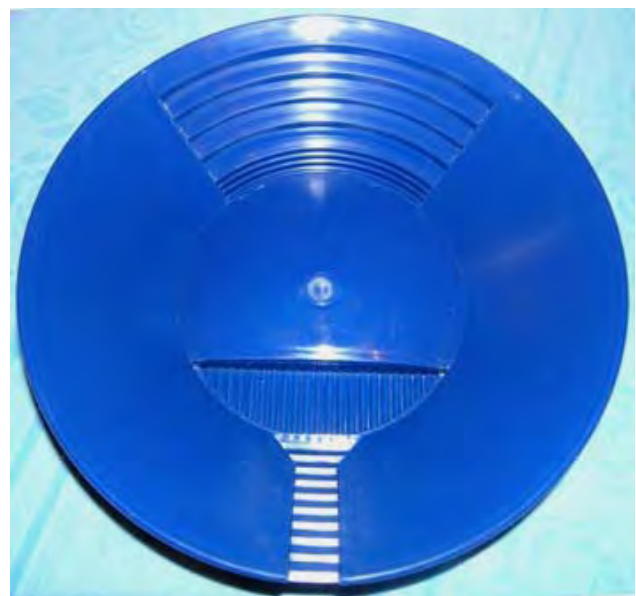

Figure 47. A Trinity Bowl showing the domed floor with riffled area in front of a riffled channel to the rim of the pan. The opposite end of the pan has more riffles, including some slot traps. (photo: Robin Grayson)

Other innovative designs

Many other designs of North American gold pans exist that are not patented and therefore arbitrarily excluded from this article yet merit study.

Innovation issues in North American gold pans

The North American gold pan has been a focus of innovators since at least the 1830s and since 1861 until the present day have been the subject on numerous US patents. Some issues troubling panners that inventors tackled with their patents include: speed; skill; labour; fine gold recovery, low cost and ease of manufacture.

Dozing, scooping and scraping

Many prospectors – especially in the past – used the pan as a dozer, scoop and scrape without recourse to spade or screen. Travelling on foot or horseback, to minimise cargo is a major accomplishment.

Made of sheet metal, often with a protective rolled-over beaded rim, early pans could doze, scoop and scrape with little risk of damage or destruction. Tobin (1900) inserted a defensive shield that improved the dozing speed, Ord (1929) added a “pick point” to his pan “to enable breaking through snow or any crust.”

The dozing and scraping capability has been largely lost by modern pans, although scooping of loose material is still usually possible. Unable to doze or scoop, the modern pan tends to be marginalised as a prospecting tool unless used in tandem with a shovel. However a shovel can be difficult to use under water and so the shovel-pan combination tends to direct the panner to dig stream banks and terraces, and so the panning process tends to be with the pan held largely out of the water rather than largely submerged as was the past custom.

Speed

Screening reduces the volume before panning, increasing the volume processed. Current fashion is to pre-screen, but many prospectors – past and present – use the pan as a dozer, scoop and scrape without pre-screening, merely avoiding boulders and rejecting oversize by hand. Pre-screening prevents the pan being used in this manner, and may cause the pan to be replaced by a rocker, small sluice or similar portable device capable of a screening and processing much larger volumes.

Some inventors insert screens in or on their pans, notably Sletcher (1897), Hardwick (1907), Nicolai (1934), Remais (1993) and Rosman (1997). This cuts the volume panned, but renders difficult viewing the pan contents and invites delay while the screen is detached for cleaning.

Wet hands

Panning with the pan submerged in a stream is tiring for a panner and invites risk of skin damage, and indeed water-borne diseases and – in cold water – numbness and frostbite. Placer companies solve this by installing panning baths (figures 49 and 50). Baths are too cumbersome for lone prospectors, solved by Ord (1913, 1919) adding handles that keep the panner's clear of the water. This innovation has been lost and merits renewed attention.

Some features of US patented gold pans										
award	inventor	patent	circular shape	screen in pan	moulded plastic	shapes in side or floor	riffles in pan wall	large riffles on floor	empty from below	suspended by cables
n/a	Trinity bowl	pending	⊙		☑	☑	☑	☑		
2003	Matt Kelava	D#475,727	⊙		☑	☑				
1997	Alexander Rosman	#5,667,076	⊙	☑	☑	☑				
1993	Robert E. Remias	#5,190,158	⊙	☑	☑	☑	☑			
1987	Leo Ottrok	#4,671,868	⊙			☑	☑			
1982	Ralph H. Morgan	#4,319,994	⊙			☑				☑
1981	Robert E. Legg	#4,273,648	⊙		☑		☑			
1981	as above - variant	#4,273,648	⊙		☑	☑				☑
1979	Roy Lagal	#4,162,969	⊙		☑	☑	☑			
1975	Manuel P. Lawrence & Kenneth F. Jacobson	#3,899,418	⊙		☑	☑	☑			
1974	Russell D. Stephenson	#3,855,119	⊙			☑				
1962	Eric S. Smith	#3,059,776	⊙			☑	☑			
1957	Bruce A. Kress	#2,797,809	⊙							
1953	Frank S. Streng	#2,630,226	⊙			☑				☑
1939	William L. Boekel	#2,178,390	⊙			☑				
1934	Joseph E. Danills	#1,972,645	⊙			☑	☑			
1934	Joseph P. Ryan	#1,966,359	⊙			☑	☑			
1934	Otto K. Nicolai	#1,948,797	⊙	☑						☑
1923	Edward O.C. Ord	#1,444,752	⊙			☑				
1922	Edward O.C. Ord	#1,419,405	⊙			☑				
1919	Edward O.C. Ord	#1,292,364	⊙			☑	☑			☑
1913	Edward O.C. Ord	#1,064,854	⊙			☑				
1913	Edward O.C. Ord	#1,064,853	⊙			☑				☑
1909	John M. White	#923,392	⊙			☑	☑			
1907	Penton A. Hardwick	#865,178	⊙	☑						
1900	John Tobin	#664,066	⊙			☑	☑			
1900	Walter George Collins	#646,382	⊙			☑				
1899	William Henry Moore	#634,120	⊙			☑	☑			
1897	Fredrick Sletcher	#585,989	⊙	☑		☑				☑
1863	Thomas Kendall Sr.	#37,758	⊙			☑	☑			☑
1861	John A. Brock	#32,115	⊙			☑				

Figure 48. Some themes seen in US patents for gold pans. Most themes began before the Great War.

Large heavy pans

One way to maximise production is to use a large pan. Indeed the traditional North American gold pan is about 18 inches in diameter. The reverse has happened with modern pans being much smaller. For every inch reduced the area reduces disproportionately and so too does the useful depth of the pan. In the past it seems a panner would use as large a pan as possible for initial rough panning and hand screening, and then tip the much reduced volume of upgraded slurry into a small pan for actual gold recovery. It follows that the small pans would also find favour by placer companies for upgrading concentrates from wash-plants and become popular among recreational miners wanting to travel light and with a requirement to upgrade concentrate from small sluices. By comparison the market for large-sized North American gold pans has dwindled and manufacture is limited.

Ord (1913a, 1913b, 1919) shows that a large heavy pan is possible – if supported by cables from above, the panner still able to control the panning motion in the normal manner but without much physical effort. This innovation has been lost and merits renewed attention.

Wet or dry panning

The traditional North American gold pan is intended for use totally submerged in water for the first part of the panning process and with copious water available for the later stages of panning, especially if troublesome clay is present.

Several inventors found ways to greatly reduce the volume of water required for the panning process. Ord shows some of his innovative designs (1922, 1923) require far less water than a normal pan. The same pans can function with dry sand – without any water at all – as can the pans of Smith (1962) and Rosman (1997). Today such know-how exists among some recreational miners but does not seem apparent among artisanal miners in the Gobi desert or other arid regions.

Gold removal from below

Scientific tests are lacking, but experienced panners assert that most gold settles during the first few swirls of the water in the pan, and most the effort and time is devoted to ditching the lights and excess water – slowly and expertly to avoid throwing out the gold also.

Several inventors circumvent this labour by inserting a gold removal mechanism to the base of the pan, notably Kendall (1863), Ord (1919), Nicholai (1934), Strenge (1953), Legg (1981) and Morgan (1982), and it is also resorted to by some inventors of hand-held to-and-fro devices such as Ashcraft (1996).

Recovery of fine gold

Most inventors claim improved recovery of fine gold using their innovation. While this may be assumed correct to a degree, the multitude of patents addressing the same issue indicated lingering dissatisfaction and failure.



Figure 49. Comfortable posture using a North American gold pan requires a panning bath, ideally a round bath to snugly accommodate a round pan. Toson Terrace Mine of Java Gold Corporation in the Zaamar Goldfield of Mongolia. (photo: Robin Grayson)



Figure 50. Comfortable posture using a North American gold pan requires a panning bath, in this instance an oblong water tank. Toson Terrace Mine of Java Gold Corporation in the Zaamar Goldfield of Mongolia. (photo: Robin Grayson)

Gold pan as candidate for BAT

Best Available Techniques

No previous assessment has been made to determine if the North American gold pan is a candidate for Best Available Techniques (BAT) in spite of its wide use.

Operational advantages

The North American pan offers many advantages:

- ✘ low operating cost if labour is cheap;
- ✘ minimal to zero capital cost (e.g. old fry-pan can be used);
- ✘ traditional pans used for digging, scraping and scooping with no need for shovel;
- ✘ before panning, easy to remove oversize from the pan and check for any large nuggets;
- ✘ motion creates and maintains water flow around the pan, enabling suspended fraction (especially clays) to be removed by deliberate decanting (spillage);
- ✘ much low density sand and silt removed by gentle panning;
- ✘ streak of black sands left as a smear on bottom of pan;
- ✘ easy to see coarse gold in the pan;
- ✘ no risk of pan being lost by sinking, if made of plastic;
- ✘ easy to use buoyancy of water to support the pan; and
- ✘ very easy to shift location quickly, and at minimal cost.

Operational disadvantages

Like other manual gold recovery devices, the north American pan has its limitations:

- ✘ labour intensive and requires skill, strength and stamina;
- ✘ fine gold is impossible to see without a good hand lens (x20);
- ✘ very fine gold cannot be seen without a microscope (x100);
- ✘ black sand can sit on top of fine gold in the pan, completely hiding the gold from view; and
- ✘ difficult in cold weather.

Environmental factors

Environmental factors for the North American gold pan are similar to other manual methods of gold recovery:

- ✘ risk to topsoil resource – not a direct factor;
- ✘ risk to mineral resource: oversize is removed manually, ensuring any large nuggets are detected; but still a risk of low % gold recovery if panning is not done properly; if too much sticky clay is present, or if the gold is very fine or flat;
- ✘ risk of dust generation – not a factor;
- ✘ risk of sheet runoff and effluent discharges – not a factor;
- ✘ acidic waters rich in heavy metals - tiny risk with placer but great with hard-rock as:
 - ★ acidic waters may result by oxidation and hydration of sulphide minerals notably pyrite (FeS₂); and
 - ★ heavy metals may endure acidic leaching and be liberated.
- ✘ risk to surface waters – risk of acidic waters and heavy metals from panning sites.
- ✘ risk to biodiversity in general – disturbance to wildlife by noise, muddy water and waste; and
- ✘ risk to freshwater ecosystem – fish feeding, migration and spawning, and the freshwater ecosystem overall, may be adversely affected by an increase in turbidity and sediment, especially if many panners in a small slow stream; and
- ✘ risk of poor land reclamation – ground may be left damaged, particularly from hummocks, shafts and tunnels abandoned by miners, and to a small degree by the tailings from pans.

Key factors in BAT determination

The key factors in assessing North American gold pans appear to be:

- ✘ moderate/good % gold recovery (but no tests reported);
- ✘ risk of effluent of muddy silty water;
- ✘ tailings with heavy metals (but stable if from normal placer);
- ✘ if hard-rock ore, a significant risk of acidic waters and leaching of heavy metals; and
- ✘ risk of water-related illnesses are a concern; and
- ✘ physical injury from strains is also a concern, but no so if:
 - ★ operator wears waterproof gloves, boots and apron;
 - ★ the water is kept at a comfortable temperature; and
 - ★ panning in a raised water bath to enable a standing posture.

Desirable modifications for BAT status

On the basis of this review of US patents, modifications to enable North American gold pans to attain BAT status are:

- ✘ toughening pans for digging to dispense with spades;
- ✘ fitting pans with screen to reducing panning effort;
- ✘ fitting pans with handles to keep hands clear of water;
- ✘ fitting large pans with cables to cut physical labour;
- ✘ using in a bath of slightly heated water in cold weather;
- ✘ conducting tracer tests to determine optimum pan design;
- ✘ further tests on pans claiming little water required;
- ✘ further tests on pans claiming dry panning is practical.

BAT assessment of North American pans

Pending detailed field observations and technical study, the provisional assessment of North American gold pans that they are potential candidates for BAT (Best Available Techniques) for manual recovery of gold, subject to a set of stringent conditions:

- ✘ if the stream is at its low-stage, do not use unless the stream is very wide even at the low-stage (but brief prospecting panning is acceptable);
- ✘ never use in ephemeral or tiny streams (but brief prospecting panning is acceptable);
- ✘ limit the number of users in a single stretch of a stream;
- ✘ never use mercury (Hg) in the pan or before or after;
- ✘ do not process ore that has significant mercury (Hg);
- ✘ do not process ore that has significant cinnabar (HgS);
- ✘ check for fine gold by hand lens (x20);
- ✘ check for very fine gold by binocular microscope (x40, preferably x100); and
- ✘ if the ore has pyrite (FeS₂) or other easily decomposed sulphide minerals, then:
 - ★ panning away from water-courses or springs;
 - ★ avoidance of large accumulations of waste;
 - ★ avoidance of mounding of waste, to minimise acidification;
 - ★ sealing waste using clay, to reduce water ingress and minimise acidification; and
 - ★ specialist determines where and how to dump waste to minimise acidification.

Discussion

Although the North American gold pan has existed for at least 150 years, the author is unaware of any scientific tests having been published on the performance of the device in recovering gold. This requires meticulous field tests and stringent laboratory testing using tracers.

To assist individuals, assessment should focus on the percentage of fine gold and flat gold that the pan is capable of recovering, particularly in comparison with other hand-held devices such as the Grizzly Pan, Le©Trap Pan, lotok, batea and dulang.

To assist companies, the precise capability and limitations of the North American gold pan merit urgent study, as this was often the only device used in determining the grade of intervals examined by prospect pits and North American churn drills (= cable drills). A correction factor for the loss of fine and flat gold needs to be estimated by tracer tests, allowing a revision to grade, resource and reserve of virgin placer and tailings.

Of interest are the large number of studies on panning as a prospecting tool for heavy minerals [11,12,13,14,15] yet do not present experimental data on the percentage recovery of fine gold or flat gold, nor any rigorous comparison of different types of pan. The same is true for books and articles that cover panning, even those with panning as a theme [16,17].

The same omission is apparent in reports on artisanal and small-scale mining (ASM) throughout the world that – at best – might include a few photographs of panning activity and pans, but avoid any hard facts on the percentage recovery of different sizes and shapes of gold. This is lamentable, as many projects aspire to combat poverty and mercury – goals difficult to attain if baseline data on the performance of pans is not gathered first. It seems to the author that the humble pan is shunned by project managers, yet from millions of ASM households understanding panning is a prerequisite to reducing poverty by raising daily income while combating mercury.

An issue is the diminishing in size of the North American gold pan over the last century. If the trend persists then by 2100 it would vanish altogether! The bigger the pan the larger the throughput and the more income per day. The innovation by Ord of suspending a large pan by cables merits fresh consideration.

Pans were originally used submerged for hand-held dredging in shallow water, by dozing, scraping and scooping, and modern designs should pay fresh attention to meeting this requirement. Otherwise the pan is used only as a low capacity washing device, rather than a combined mining and washing device.

Keeping the panner's hands out of water, particularly cold water, merits fresh attention of inventors, following the lead of Ord whose rods kept the panners hand clear of the water for most of the time.

It is said that most gold settles to the bottom of the pan during the first few swirls, so effort should be redoubled to find a reliable means of emptying the gold from below, with potential huge increase in panning speed as then all the pan contents can be ditched immediately.

Acknowledgements

The author is pleased to acknowledge the valuable contributions and assistance given by the following people and organisations:

Thanks are due to Dr. Baatar Tumenbayar, Minjin Batbayar MSc and Mrs Chimed-Erdene Baatar MBA (Eco-Minex International Ltd) for ideas and assistance in the field. Nurlan Djoldoshev and colleagues in the Tacis SME project and AVISTA showed artisanal miners using pans in Kyrgyzstan. Special thanks are due to many members of the Alaska Gold Forum for ideas and advice.

This study was made possible by support from Eco-Minex International Ltd.

References

1. Michael Priester, Thomas Hentschel and B. Benthin (1993). Tools for Mining, Techniques and Processes for Small Scale Mining. GATE, Vieweg-Verlag, 537 pages.
View: <http://sleekfreak.ath.cx:81/3wdev/CD3WD/APPRTech/G10TOE/INDEX.HTM>
2. Clive Aspinall (2001). Small-Scale Mining in Indonesia. MMSD International Institute for Environment and Development (IIED), London, report #79, 30 pages.
Download: www.iiied.org.
3. Pujol, Yvan (date?) Batee and Pans.
Read: <http://pujol.chez-alice.fr/matos/pans.html>
4. Robin Grayson (2006). Gold recovery in cones in Laos – the term 'dulanging'. World Placer Journal, volume 6, pages 36-41.
Download: www.mine.mn
5. Chimed-Erdene Baatar (2006). Gold recovery in bowls in Mongolia – the term 'bowling'. World Placer Journal, volume 6.
Download: www.mine.mn
6. Robin Grayson (2006). Gold recovery in buckets in Kyrgyzstan – the term 'bucketing'. World Placer Journal, volume 6.
Download: www.mine.mn
7. Robin Grayson (2006). Gold recovery in wooden trays in Russia – the term 'lotoking'. World Placer Journal, volume 6, pages 22-35.
Download: www.mine.mn
8. Chimed-Erdene Baatar (2006). Gold recovery on mats in Mongolia – the term 'matadoring'. World Placer Journal, volume 6.
Download: www.mine.mn
9. Clarence W. Ashcraft (1996). Hand held classifying device. [Grizzly Pan]. United States Patent # 6,095,342 awarded 1st August 2000, United States Patent and Trademark Office, 5 pages.
Download: www.uspto.gov
10. Pro Gold Prospecting Equipment & Supplies, Arizona [Trinity bowl]:
View: www.trinitybowl.com
11. Paul Kellogg Theobald Jr. (1956). The gold pan as a qualitative tool. United States Geological Survey USGS Trace Element Investigation Report #487, 72 pages.
Download: <http://pubs.er.usgs.gov>
12. Paul Kellogg Theobald Jr. (1957). The gold pan as a quantitative tool. United States Geological Survey USGS Bulletin #1071-A, 54 pages.
13. John Beaver Mertie Jr. (1954). The gold pan: a neglected geological tool; Economic Geology, volume 6, pages 639-651.
14. G. Zeschke (1961). Prospecting for Ore Deposits by Panning Heavy Minerals from River Sands. Economic Geology, volume 56, pages 1250-1257.
15. R.P. Fischer and F.S. Fischer (1970). Interpreting Pan Concentrate Analysis of Stream Sediments in Geochemical Exploration for Gold. United States Geological Survey USGS Circular #592.
16. Roy Legal (XXXX). Gold Panning Is Easy. 84 pages.
Purchase from: www.akmining.com/cart/bookgoldmining.htm
17. J.H. Wells (1969). Placer Examination: Principles and Practice. Bureau of Land Management Technical Bulletin #4. 209 pages.
Purchase from: www.akmining.com/cart/bookgoldmining.htm